

POWERNAIL® CO.

Powernail® Model 445FS STAPLER with Power Roller



OPERATION AND MAINTENANCE MANUAL MANUAL DE OPERACION Y DE MANTENIMIENTO MANUEL D'INSTRUCTIONS ET D'ENTRETIEN

WARNING



Read this manual before you use this PowerStapler®. Follow all safety warnings and instructions. If you are uncertain about the operation of the stapler, call us directly at 1-800-323-1653 for assistance or contact the closest Powernail Dealer for help. Please retain this information for future reference.

INTRODUCTION

The Model 445FS Stapler with Power Roller is a state-of-the-art pneumatic Powerstapler® designed to bring flexibility and speed to tongue & groove flooring installation.

The Model 445FS Power Roller is designed for use with 2", 1-3/4" and 1-1/2" (15.5 gauge) Powerstaples® nails and can nail down from 3/4" to 5/8" tongue and groove hardwood flooring.

For superior pneumatic flooring tools, look to the company that has been the industry's leader in quality—POWERNAIL® COMPANY, INC.

INDEX

Index.....	2	Seal Locations Diagram.....	10
Warranty.....	2 & 16	Schematic	11
Safety Instructions.....	3	Safety Labels.....	12
Operating Instructions.....	4	Troubleshooting Chart.....	13
Parts & Service.....	5-7	Depth Chart.....	14
Drive Blade Change.....	6	Accessory Products.....	15
Seal Replacement.....	6-7		
Parts List.....	8-9		

LIMITED WARRANTY

POWERNAIL® Company, Inc. warrants to its customer, and to the first end-use purchaser of POWERNAIL flooring nailers purchased from an authorized POWERNAIL distributor, that each serialized manufactured nailer by POWERNAIL®, for a period of 12 months from the date of purchase, and with respect to the nailer/stapler body (specifically Models 200, 445, and 50P), for a period of 10 years from date of purchase, ("warranty period"); shall be free of defects in materials and workmanship and will meet POWERNAIL's specifications in effect at the time of Product shipment. POWERNAIL will repair or replace, at its option, any Powernailer® that does not conform to this warranty. Claims must be made no later than fifteen (15) days after the end of the warranty period. POWERNAIL will perform all repair or replacements itself or through its authorized contractors. POWERNAIL is not responsible for shipping, labor or other direct or indirect costs. Damage caused by abuse, misuse, unusual or excessive wear is excluded. Repair or modification of the Products by unauthorized parties will void this warranty. The customer is responsible for returning Products to POWERNAIL for verification of nonconformance. Warranties for Products not manufactured by POWERNAIL are limited to warranties provided to POWERNAIL by the manufacturer of such product that are assignable to customer.

THESE WARRANTIES AND REMEDIES ARE EXCLUSIVE OF ALL OTHERS, EXPRESS OR IMPLIED. THE WARRANTIES OF MERCHANTABILITY AND FITNESS FOR PURPOSE ARE EXPRESSLY EXCLUDED. IN NO EVENT SHALL POWERNAIL'S LIABILITY FOR A WARRANTY CLAIM EXCEED THE PRICE PAID TO POWERNAIL FOR THE NONCONFORMING PRODUCT, REGARDLESS OF THE FORM OR BASIS OF THE CLAIM OR CAUSE OF ACTION.

SAFETY INSTRUCTIONS



Always use approved **SAFETY GLASSES** and **EAR PROTECTION** when operating this stapler. The operator and others in the work area should always wear approved **FRONT** and **SIDE** eye protection when operating this stapler. Eye protection will help guard against flying staples and debris, which could cause severe eye injury.



EYE AND EAR PROTECTION should be used to prevent hearing damage when there are high noise levels in the work area.

ALWAYS use ear plugs with a noise reduction rated at 29 db or higher at a construction site.

Stapler noise ratings are at LPA-1sd=90.6,
LWA-1sd=99.3 and LPA-1s,1m=86.3.
Stapler vibration rating: m/s²=3.05.

Always **DISCONNECT THE AIR SUPPLY** before making any adjustments, repairing, clearing jams or when the stapler is not in use. Do not use on scaffolding or ladders and disconnect stapler from air supply when transporting between installation areas.

Never attach the female end of a quick disconnect to the stapler. This will trap air inside the Stapler and permit it to be discharged. Only the unrestricted male connection should be attached to the Stapler.

Stapler requires an air source that can continuously deliver 80 to 110 psi at 3-1/2 cubic feet of air per minute for operation.

Normal air pressure should not exceed 120 psi or damage to the Stapler and seals may occur. Excess air pressure can cause the Stapler to explode.

To prevent fire or explosion, use only regulated compressed air—do not use bottled gases of any kind (no oxygen or combustible gasses) to power this Stapler.

Stapler is intended for use installing wood flooring and is not to be used for purposes not specified in the operations manual.

Do not use any staples other than Powernail Powerstaples Staples which are specifically designed for use in any Powerstapler. Powerstaples Staples are available in various lengths. Contact your Powernail Dealer for Powerstaples Staples.

Use only Powernail replacement parts in the repair or maintenance of this stapler. Parts or repair services are available from the manufacturer or from agents authorised by the manufacturer. Repairs should be carried out only by trained service personnel in the field of fastener driving tools who will observe proper safety controls while performing maintenance. Service personnel should be qualified to assess the safe working condition of fastener driving tools.

Never place any part of the body in the discharge path of the Stapler when air is connected to the Stapler. Always make sure Stapler is empty of cleats before connecting air hose so as to prevent any accidental discharge from occurring.

Never leave the Stapler unattended while it is connected to an air supply.

Whenever air is connected to the Stapler, keep body parts away from the nail discharge path.

Disconnect the air line before making adjustments or repairs on the Stapler. Only connect air to an unloaded Stapler so as to prevent accidental discharge.



POWERNAIL COMPANY, INC.
1300 Rose Road, Lake Zurich, IL 60047 US
Phone: 1-800-323-1653 OR 847-847-3000
www.powernail.com

OPERATING INSTRUCTIONS

Read these instructions carefully before you use the Stapler.

To use the Powernail Flex Power Roller, adjust the stapler FLEX foot to a sample of your flooring (Figure 1).

When the stapler foot is adjusted to your flooring, simply place the stapler on the floor and pull stapler back so the 9mm rollers catch the edge of the floor above the tongue. Tap the plunger with the rubber-capped mallet-end to let the stapler drive and set the staple at the correct 45 degree angle.

FLEX Power Roller Foot Adjustment:

Wood varies from one manufacturer to the next. The different wood profiles may be due to height and length of the flooring tongue and whether or not there is a staple pocket.

First, loosen the two hex bolts under the FLEX foot with the Allen Wrench supplied with the stapler. (Figure. 1.)

Next, set the stapler on a sample of your flooring.

Use the adjustment lever at the back of the stapler foot to raise or lower the stapler to the wood.

Match the Adapter Foot 9mm rollers so that it is pointing into the 90° angle created by the tongue and the top of the wood (see Figure 2).

For wood with a staple pocket, line up the 9mm rollers at the top of the staple pocket.

When the adjustment lever is in the correct position for your wood sample, tighten the two hex bolts to lock the FLEX foot into place.

Always check your adjustment with a sample to ensure the staple is driving into the staple pocket.

To Load the 445FS FLEX Power Roller:

Place up to two sticks (90) of Powerstaples® (15.5 gauge) staples, 2" , 1-3/4" , or 1-1/2" long into the staple channel feed slot. Pull back the spring loaded staple pusher over the staples until it contacts the last staple and slowly release the staple pusher.

To Unload

To remove staples from the Staple Channel, pull the two round knobs on the Staple Pusher together. This will clear it from the staple path. Then turn the Stapler over so the staples slide out of the channel.

Figure 1. **FLEX Adjustment Lever**

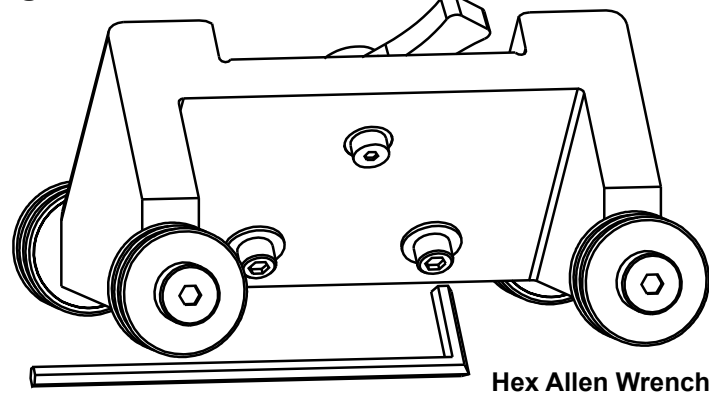

1. Loosen 2 hex screws.
2. Raise or lower the FLEX to your wood sample.
3. Match the 9mm rollers to the staple pocket.
4. Tighten 2 hex screws.
5. Test wood sample with new adjustment.

Figure 2.

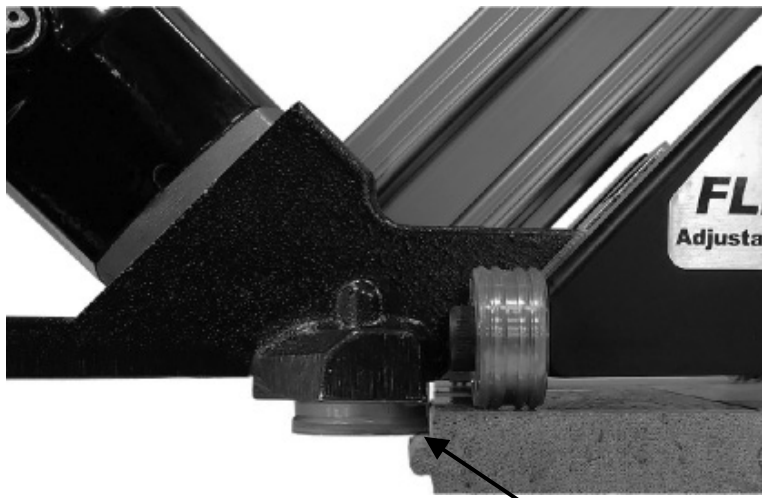

Adjust FLEX lever so the 9mm rollers are above the flooring tongue

OPERATING INSTRUCTIONS, *continued*

WARNING: It is not necessary to hit the Stapler hard to activate it. Never hit the Stapler with excessive force or with the metal end of the mallet, this will damage the Stapler.

DO NOT USE THE METAL END OF THE MALLET TO STRIKE THE PLUNGER, use the rubber capped end only.

Before each use, check all screws to be sure they are tight. Shock and vibration can loosen screws. Do not over tighten any screw.

AIR SUPPLY:

The air must be clean and dry. Dirty and/or wet air will damage the Stapler.

Drywall Dust:

- Using Pneumatic PowerStaplers in drywall dust conditions will dramatically decrease the life of the Stapler.
- Drywall dust is abrasive, when cycled through the Stapler it will cause excessive wear.

The air source must continuously deliver 80 to 110 psi at 3-1/2 cubic feet of air per minute to operate the Stapler. For operation, connect a 1/4" minimum internal diameter and clean air hose to the Stapler. Be sure the air regulator is set at 90 psi. If the staple is not countersunk below the surface of the wood, turn up the air pressure, but not over 110 psi.

Check for air supply leaks that waste air and starve the Stapler of air thereby reducing its performance. There should be no orifice smaller than 1/4" in the air path between the Regulator and the Stapler.

LUBRICATION:

You must lubricate the Stapler manually. The frequency of lubrication is dependent upon the duty cycle of the Stapler. Continuous duty requires more frequent oiling than intermittent duty.

At least every eight (8) hours place two to four drops of Air Tool Oil, supplied with your Stapler, into the disconnected air line male connector attached to the Stapler.

WARNING: Do not over lubricate the Stapler, excess oil mist or drops will be vented with spent air when over lubricated. Excess oil could stain the wood flooring, walls or furnishings. Dry fire the Stapler, without staples, to purge excess oil, before you begin to staple down flooring. Before storing the Stapler, lubricate and cycle the Stapler in insure internal parts are oil protected from corrosion.

WARNING: Detergent oil is not recommended and may damage the seals.

TO LOAD MODEL 445FS:

Place two sticks (90 PowerStaples) into the Staple Channel feed slot. Pull back the spring loaded Staple Pusher over the staples until it contacts the last staple and slowly release the Staple Pusher.

TO UNLOAD MODEL 445FS:

To remove staples from the Staple Channel, pull the two round knobs on the Staple Pusher together. This will clear it from the staple path. Then turn the Stapler over so the staples slide out of the channel.

PARTS & SERVICE:

When ordering parts include the part number, part description, PowerStapler model and serial number. Be sure to state the quantity of the part(s) required. Contact your Powerstaple Dealer for the necessary parts.

WARNING: Never work on the Stapler if the air line is attached. Always disconnect the air line from the Stapler first.

Stapler DISASSEMBLY:

TO REPLACE RUBBER BUMPER (#24):

1. Disconnect the air supply
2. Remove the four (4) cap screws holding the Adapter Foot, Foot and Staple Channel assembly to the main Body.
3. Pull the Rubber Bumper out of the cylinder bore. Replace the old Bumper if it shows signs of wear or it is split.
4. Reverse these steps to reassemble the Stapler. Be sure to align the Driving Blade with the slot in the Staple Channel Assembly while you reassemble the Stapler. NEVER FIRE THE Stapler WITHOUT THE RUBBER BUMPER INSTALLED, IT WILL SEVERELY DAMAGE THE STAPLER.

CHANGING A DRIVING BLADE (#15):

1. Disconnect the air supply.
2. Remove the four socket head cap screws(#40) holding the Adapter Foot(#60), Foot(#30) and Staple

OPERATING INSTRUCTIONS, continued

Channel Assembly(#27) to the body.

3. Remove the Rubber Bumper(24).
4. Pull the Driving Blade(#15) with pliers until the Piston(#20) is fully extended outward towards the bottom of the cylinder.
5. Use a 15/16" box wrench (Part #: 09-445-29768) to unscrew the Driving Blade Jam Nut(#22) and remove it. Hold the Piston from turning while unscrewing the Jam Nut by holding the piston hex with a 1-1/8" box wrench (Part #: 09-445-29768).
6. Push out the 1/4" diameter blade retaining Dowel Pin(#14) and remove the broken Driving Blade stub.
7. Install a new Driving Blade in the slot and replace the Dowel Pin(#14). Screw on the retaining Jam Nut(#22) using the same tools. If the Jam Nut becomes worn and loose after frequent removals, it should be replaced.
8. Check the fit, there should be some sideways movement between the Driving Blade and the Jam Nut assembly. This is desirable and helps the blade to align itself with the mating parts.
9. Reassemble the components. Be sure to align the Driving Blade with the slot in the Adapter Foot Assembly.

SEAL REPLACEMENT: There are 7 seals that may require replacement. We recommend that you have your PowerStaple Dealer replace the Seals.

SEAL KIT: You may choose to buy a Seal Replacement Kit and replace the seals yourself. It is good practice to replace all seals at one time regardless if only one seal needs replacement.

SEAL DESCRIPTION & NUMBER:

1. Rubber Seat (#18)
2. Plunger Seal Set (#10)
3. Piston U-Cup Lip Seal (#21)
4. Return Cylinder U-Cup Lip Seal (#17)
5. Piston Rod U-Cup Lip Seal (#12)
6. Plunger Wiper Seal (#4)
7. Return Cylinder O-Ring Gasket (#11)

To change Seals follow these procedures. Be sure the air line is disconnected from the Stapler first before making any repairs. Consult the illustration for the name and location of the following component parts.

SEAL REPLACEMENT REQUIRES REMOVAL OF THE DRIVING BLADE ASSEMBLY:

1. Disconnect the air supply.
2. Remove Rubber Plunger Cap (#7).
3. Unscrew & remove Body Cap (#2).
4. Unscrew the three #10-32 cap screws holding the Plunger (#9) to the Return Cylinder (#16).
5. Pull the Plunger up and out of the Stapler Body (#1) cavity.
6. Remove the Return Cylinder O-Ring Gasket (#11) located on the top of the Return Cylinder under the Plunger.
7. Turn the Stapler over and remove the four cap screws

(#3), that fasten the Adapter Foot and Staple Channel Assembly to the Stapler Body and lift the Assembly off the Body.

8. Remove the Rubber Bumper (#24).
9. Pull the Driving Blade Assembly out of the Stapler Body by pulling on the Driving Blade.
10. Hold the Piston Rod (#13) with an 11/16 socket over its hex end opposite the Piston. **Do not use pliers or a vise anywhere on the metal parts, they can damage the sealing surfaces.**
11. Use box wrenches to remove the 5/8-18 Jam Nut (#22). Remove the Dowel Pin (#14) and Driving Blade (#15).
12. Unscrew the Piston from the Piston Rod using box wrenches and separate the Piston, Piston Rod and Return Cylinder.

TO REPLACE THE SEALS:

Rubber Seat (#18):

1. Remove the Cylinder Sleeve (#23). The Cylinder Sleeve should slide out of the Stapler Body when you pull out the Driving Blade Assembly.
2. Remove the metal Support Ring (#19) and Rubber Seat from inside the Stapler body. Note that the chamfer on the inside of the Rubber Seat faces the BOTTOM of the Stapler, do not reverse the direction of the chamfer when you replace the Rubber Seat.
3. Replace the Rubber Seat, Support Ring and Cylinder Sleeve. Be sure to re install the steel Cylinder Sleeve with the chamfered inside edge facing the BOTTOM of the Stapler

Plunger Seal Set (#10):

1. Remove the Teflon[®] Seal and its O-Ring expander from the groove using a bent paper clip or pick. Be sure not to scratch the inside walls of the seal groove with the wire hook.
2. Clean out the seal groove. Place a new O-Ring into the seal groove by stretching it over the Plunger body. Make sure the O-Ring is not twisted in the groove. Place a new Teflon[®] Seal Ring into the seal groove over the O-Ring.
3. Carefully push the Teflon[®] Seal Ring over the edge of the Plunger with your thumbs and into the groove. Do this as quickly as possible to reduce stretching of the Teflon[®] Seal Ring. **DO NOT OVER STRETCH THE TEFLON[®] SEAL RING!** Be sure the Teflon[®] Seal Ring is centered all around the seal groove and not twisted.
4. Wipe off the Seal surface with a clean rag and lubricate it generously with Pneumatic Light Air Tool Oil lubricant.

Piston U-Cup Lip Seal (#21):

1. Remove the old Piston U-Cup Lip Seal from the Piston using a bent paper clip or pick, being careful

OPERATING INSTRUCTIONS, continued

not to scratch the inside walls of the seal groove or the edge of the Piston with the wire hook.

2. Clean out the seal groove. Place a new U-Cup Lip Seal into the groove. Make sure the lips is not twisted in the groove and the lips face the top of the Stapler See the sketch below.

3. Carefully wipe off the U-Cup Lip Seal surface with a clean rag and lubricate it generously with Pneumatic Light Air Tool Oil lubricant.

Return Cylinder U-Cup Lip Seal (#17):

1. Use a bent paper clip or pick to remove the old U-Cup Lip Seal from the internal seal groove inside the Return Cylinder. Be careful not to scratch the inside walls of the seal groove with the wire hook.

2. Clean out the seal groove. Place a new U-Cup Lip Seal into the groove, be sure it is not twisted in the groove. Be sure the lips are facing the inside of the Return Cylinder as shown in the schematic (page 10-11, 13).

WARNING: The U-Cup Lip Seals (#3) and (#4) look alike, but they are different, DO NOT mix them up.

3. Carefully wipe off the Lip Seal surface with a clean rag and lubricate it generously with Pneumatic Light Air Tool Oil lubricant.

Piston Rod U-Cup Lip Seal (#5):

1. Remove the old U-Cup Lip Seal from the seal groove with a bent paper clip or pick using care not to scratch the inside walls of the seal groove with the wire hook.

2. Clean out the seal groove and install a new U-Cup Lip Seal. Be sure the Lips are facing the right direction and are not twisted in the groove. See the sketch below.

WARNING: The Lip Seals (#3) and (#4) look alike, but they are different, DO NOT mix them up.

3. Carefully wipe off the seal surface with a clean rag and lubricate it generously with Pneumatic Light Air Tool Oil lubricant.

Plunger Wiper Metal Cap O-Ring (#4):

1. Use a bent paper clip to pick out the felt Wiper Seal out of its groove in the Body Cap (#2).

2. Clean out the groove and insert the new O-Ring (#6) in to the groove in the metal body cap (#2).

Return Cylinder O-Ring Gasket (#11):

1. Place a new O-Ring Gasket in the groove on top of the Return Cylinder when you reassemble the Driving Blade Assembly.

2. Wipe off the O-Ring Gasket seal surface and lubricate it generously with Pneumatic Light Air Tool Oil lubricant.

REASSEMBLING THE Stapler:

1. Be sure the Rubber Seat, Support Ring and

Cylinder are installed in the Body and are facing the correct way.

2. All seal surfaces must be clean and lubricated generously with Pneumatic Light Air Tool Oil lubricant.

Replace any part that shows signs of wear.

3. Use care when installing the seals into their respective cavities. Be sure the Seals are contained in their groove and do not come out as the parts slide together. Generous cavity lead in chamfers have been provided to help Seal installation.

4. Carefully insert the Piston Rod into the return Cylinder and screw the Piston onto the rod. Be sure the Piston is facing the correct way, ears up, hex down.

5. Assemble the Driving Blade, Dowel Pin and Jam Nut on to the Piston Rod.

6. Insert the Driving Blade Assembly up into the bottom of the Stapler Body Cylinder.

7. Be sure there is a new O-Ring Gasket in the top groove of the Return Cylinder.

8. Insert the Plunger into the top cavity of the Body. Line up the holes and install the three Plunger retaining screws. It is important that the three #10-32 screws are tight or air leakage will occur. Our recommendation is to use 1-2 drops of blue Loctite® or similar on the 3 screws.

9. Install the Body Cap and Plunger Rubber Cap.

10. Turn the Stapler upside down. Install the Rubber Bumper, Staple Channel Assembly and Adapter Foot. Be sure to align up the Driving Blade with the slot in the Foot before the Stapler is closed up.

11. NEVER FIRE THE Stapler WITHOUT THE RUBBER BUMPER INSTALLED, IT WILL DAMAGE THE Stapler.

TO CLEAR A Staple JAM:

1. It helps to tap the Driving Blade back to the retracted position before trying to remove a jammed staple. A spare Driving Blade works best for this.

2. Try to pull the jammed staple out of the gate with a pair of long nose pliers. If this does not work remove the four (4) cap screws holding the Foot, Gate and Staple Channel Assembly together.

3. Separate the Foot and gate with a screw driver just enough to clear out the jammed staple.

4. Put thread locking compound on all screws and reassemble the components.

**For Step-by-Step Videos and Instructions,
Visit our Web Site at: www.Powernail.com**

MODELS 445FS POWER ROLLER PARTS LIST

ITEM	PART NO.	DESCRIPTION	QTY REQ	TU	SEAL	AVAIL
1	09-44529320	BODY	1			F
2	09-445293150	CAP (LOW PROFILE)	1			S
3	09-50P3202	1/4-20 X 5/8" S.H.C.S. W/PATCH (CAP)	4			S
4	09-44529729	PLUNGER WIPER METAL CAP O-RING	1	TU	SEAL	S, A-5, A-25
5	09-44529759	3/8" NPT 45° STREET ELBOW	1			S
6	09-4455418	1/4" AIR FITTING 3/8" NPT	1			S
7	09-44529722	RUBBER CAP	1	TU		S, A-25
8	09-44529832	#10-32 X 3/4" S.H.C.S. W/PATCH (PLUNGER)	3			S, A-11
9	09-50P3014	PLUNGER (LOW PROFILE)	1			S, A-11
10	09-44529725	PLUNGER SEAL SET	1	TU	SEAL	S, A-5, A-11, A-25
11	09-44529731	RETURN CYLINDER O-RING GASKET	1	TU	SEAL	S, A-5, A-11, A-25
12	09-2003028	PISTON ROD U-CUP SEAL	1	TU	SEAL	S, A-5, A-11, A-25
13	09-44529710	PISTON ROD	1			S, A-11
14	09-44529740	1/4" X 1/2" DOWEL PIN (DRV. BLADE)	1	TU		S, A-11, A-25
15	09-44529303	DRIVING BLADE	1	TU		S, A-11, A-25
16	09-44529830	RETURN CYLINDER	1			S, A-11
17	09-2003027	RETURN CYLINDER U-CUP SEAL	1	TU	SEAL	S, A-5, A-11, A-25
18	09-44529723	RUBBER SEAT	1	TU	SEAL	S, A-5, A-11, A-25
19	09-44529721	SUPPORT RING	1			S
20	09-44529711	PISTON	1			S, A-11
21	09-2003026	PISTON U-CUP SEAL	1	TU	SEAL	S, A-5, A-11, A-25
22	09-44529748	5/8-18 JAM NUT (DRV. BLADE)	1	TU		S, A-11, A-25
23	09-44529715	CYLINDER SLEEVE	1			S
24	09-44529724	RUBBER BUMPER	1	TU		S, A-11, A-25
25XL	09-50P3201	HANDLE, X-LONG	1			S
25L	09-50P3200	HANDLE, LONG	1			S
26	09-50P3202	1/4-20 X 5/8" S.H.C.S. W/PATCH (HANDLE BASE)	4			S
27	09-44529325	TWO PART CHANNEL W/ TWO B.H.C.S	1			S, A-9
28	09-44529330	GATE	1	TU		S, A-9, A-25
29	09-44529305	GATE PLATE	1	TU		S, A-9, A-25
30	09-44529706	FOOT	1			S, A-9
31	09-44529331	#10-32 X 1/2" S.H.C.S. (STANDOFF)	1			S, A-9
32	09-44529756	1/4 X 1 STANDOFF SPACER (CHANNEL)	1			S, A-9
33	09-44529327	#8-32 X 5/16 B.H.C.S. (CHANNEL)	1			S, A-9
34	09-44529317	#10-32 X 1" S.H.C.S. W/PATCH (FOOT)	4			S, A-9
35	09-44529836	#10-32 X 3/8" S.H.C.S. (GATE)	2	TU		S, A-9
36	09-44529313	#6-32 X 1/2" F.H.C.S. (GATE)	2	TU		S, A-9, A-25
37	09-44529326	STAPLE PUSHER SPRING	1			S, A-9
38	09-44529328	#8-32 X 1/4 F.H.C.S. (CHANNEL)	1			S, A-9, A-10
39	09-44529329	STEEL STAPLE PUSHER	1			S, A-9, A-10
40	09-44529747	1/4-20 X 1-1/4" S.H.C.S. (FOOT)	4			S, A-9, A-10
41	09-44529758	1/4" SPLIT RING LOCK WASHER (FOOT)	4			S, A-9, A-10

MODELS 445FS POWER ROLLER PARTS LIST

ITEM #	PART NO.	DESCRIPTION	QTY REQ	TU	AVAIL
60	09-4453120	ROLLER ADAPTER FOOT (445FSX)	1		S, A-3,A-16
63	09-50P3077	#10-32 X 1/2" B.H.C.S.	2		S, A-3,A-16
64	09-50P3104	ROLLER BEARING (9MM) W/ MOLDED COVER	2		S, A-1, A-2, A-3,A-16
65	09-50P3103	ROLLER AXLE (FOR ROLLER)	2		S, A-3,A-16
66	09-44529334	FLEX FOOT BRACKET	1		S, A-3
67	09-50P3073	FLEX FOOT CAM PLATE	1		S, A-3,A-16
68	09-50P3072	FLEX FOOT CAM	1		S, A-3
69	09-50P3079	BELLEVILLE DISC SPRING	1		S, A-3
70	09-50P3078	1/4 SH DIA X .50" SH. BOLT (W/PATCH)	1		S, A-3
71	09-44529875	ROLLER FLEX FOOT (445)	1		S, A-3
72	09-50P3076	WASHER .281 IDX.62 ODX.051" T	2		S, A-3
73	09-50P3075	1/4-28 X 1-1/4" S.H.C.S.	2		S, A-3
74	09-50P3097	LARGE ROLLER BEARING WITH MOLDED COVER	4		S, A-2, A-3
75	09-50P3084	ROLLER BOLT (10MM SH DIA X 16MM SH)	4		S, A-3
	09-44529801	HEX WRENCH 3/16 (FLEX FOOT)	1		A-3, A-24
	09-44529802	HEX WRENCH 5/32	1		A-24

KEY: S=Sold Separately, A= Sold as part of assembly, TU=Tune-up Kit, F=Factory replacement only, or Seal Kit.

Model 445FS Power Roller Assemblies, Kits and Accessories

ITEM #	PART NO.	DESCRIPTION	QTY REQ
A-1	09-50P3104A	9MM BEARINGS W/ MOLDED COVERS (SET OF 2)	1
A-2	09-RB15FSA	COMPLETE ROLLER SET (4 LRG ROLLERS + 2 9MM ROLLERS)	1
A-3	06-99607	445 / 445FS POWER ROLLER CONVERSION KIT	1
A-4	09-44529757A	6 OZ. AIR TOOL OIL	1
A-5	09-2003058A	SEAL KIT (1 EACH OF ALL SEALS)	1
A-9	09-44529365A	STAPLE CHANNEL ASSEMBLY	1
A-10	09-44529366A	STAPLE PUSHER ASSEMBLY	1
A-11	09-44529364ALP	DRV. BLADE ASSEMBLY W/RUBBER SEAT (W/ LOW PROFILE PLUNGER)	1
A-15	09-44529768	BOX WRENCH - 2 ENDS: 15/16" & 1-1/8" (2 REQ)	2
A-16	09-4453120A	ROLLER ADAPTER FOOT ASSEMBLY	1
A-24	09-AW445	ALLEN WRENCH SET (3/16 FLEX FOOT AND 5/32)	1
A-25	09-445FSTUKIT	MODEL 445FS TUNE UP KIT	1

For this parts list and other Powernailer schematics, please visit the
Powernail Parts Store at <http://www.powernail.com>

Pneumatic Seal Part Numbers and Locations

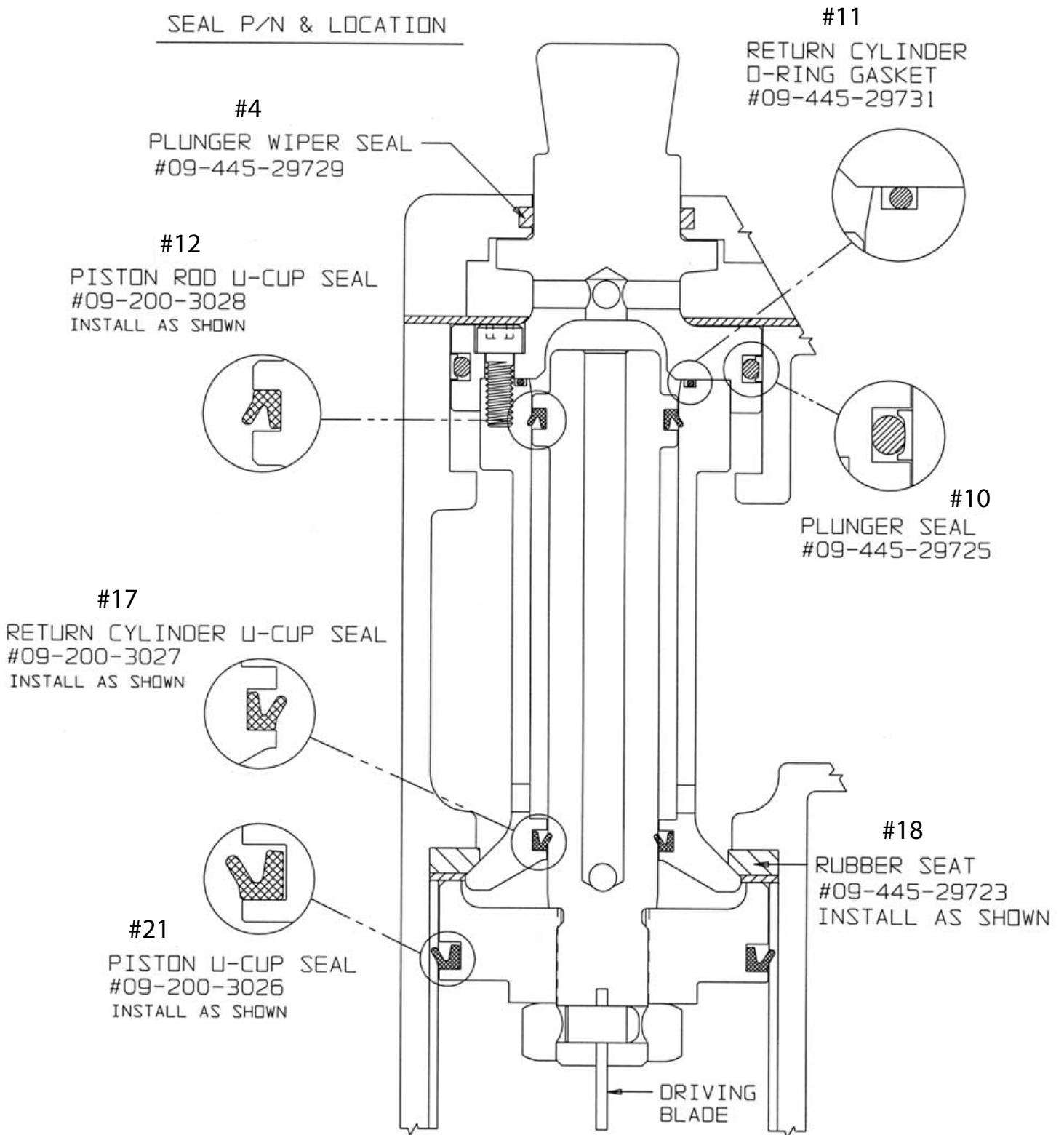

SCHEMATIC - Model 445FS Power Roller

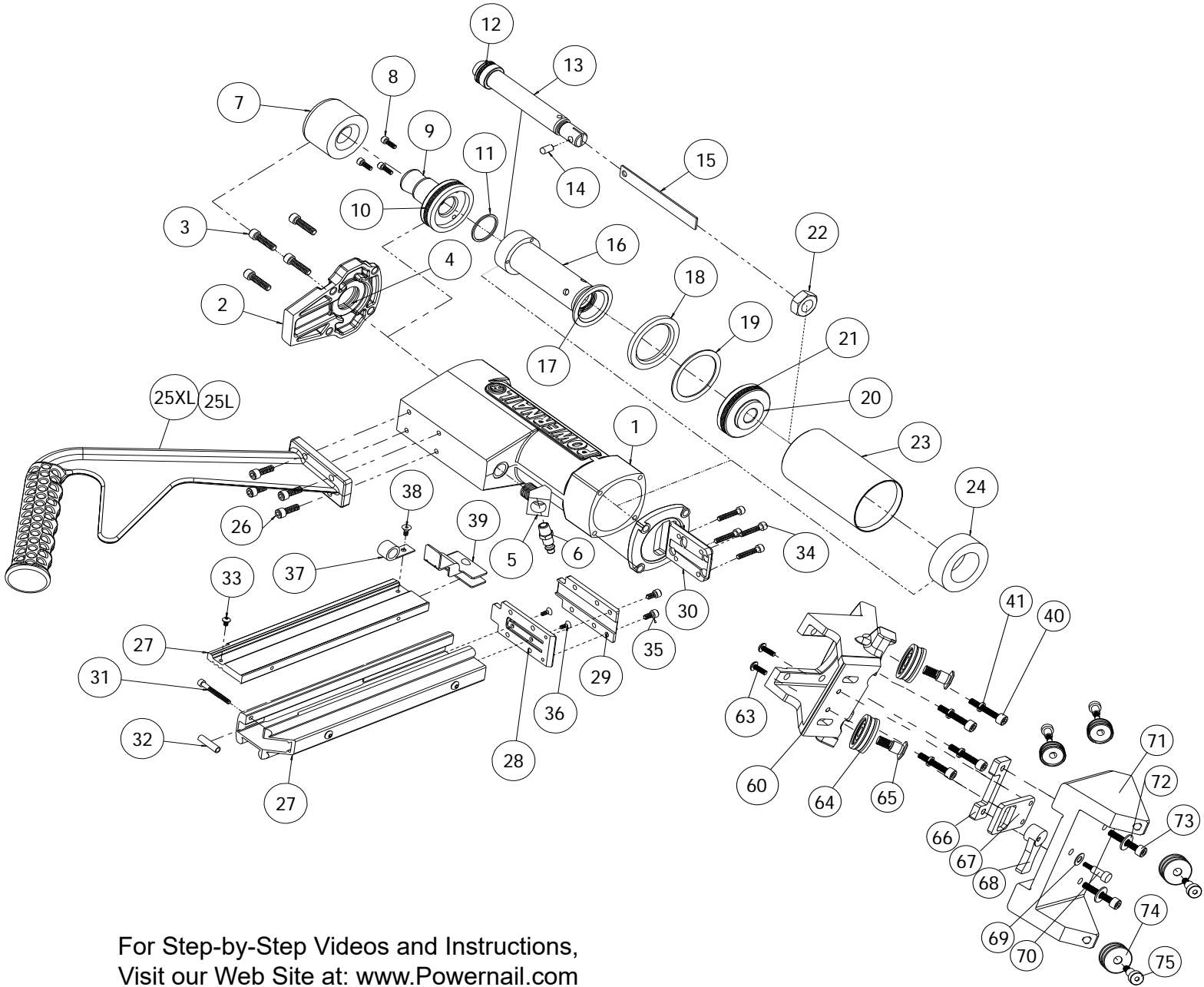

For Step-by-Step Videos and Instructions,
Visit our Web Site at: www.Powernail.com

FLEX Power Roller Conversion Parts.

Kits Available - For use on the Model 445FS Stapler

Seal Kit (1 Each Of All Seals)	Tune-up Kit
Part #: 09-2003058A Schematic #'s: 4, 10, 11, 12, 17, 18, 21	Part #: 09-445FSTUKIT Schematic #'s: 4, 7, 10, 11, 12, 14, 15, 17, 18, 21, 22, 24, 28, 29, 35, 36

NAILER SAFETY DECALS

Warning!



• Read and understand the tool labels and manuals before operating. • Operators and others in work area **MUST** wear **EYE** and **EAR** protection. • Use safety glasses with side shields. • **NEVER** point tool at yourself or others in the work area. • Only connect air to an unloaded tool and always keep tool pointed in a safe direction. • Disconnect air when clearing jams, servicing or when tool is not in use. • Use only clean, dry, regulated air not exceed 110 psi. • Never use oxygen or other bottled gasses-explosion may occur.

CAUTION:
Lubricate
Nailer with
2-4 drops of
Industrial Light
Oil for every
8 hours of use.

↑
R
E
L
O
A
D

Refill the nail channel with a clip of Powercleats when empty.

Pull the Nail-Pusher assembly to the back of the channel when cleats are reloaded.



Nailer is activated by striking the plunger. Do not work on scaffolding, ladders, elevated or uneven surfaces where the nailer could fall and self-activate. Do not leave air attached to the Nailer when moving from one install location to another.

PowerStapler 445FS Trouble Shooting Chart

	PROBLEM	POSSIBLE CAUSE	SOLUTION
1	Driving blade does not retract	1. Zero or Low air pressure	Check air supply for 80 psi minimum to 110 psi maximum
		2. Lack of lubrication	Manually lubricate through male air inlet fitting
		3. Excessive dirt inside Stapler	Disassemble and clean
		4. Bent or burred driving blade	Replace driving blade (15)
		5. Seals worn out	Replace all seals (Seal Kit A-5)
		6. U-Cup Lip Seals installed upside down	Replace all seals (Seal Kit A-5)
		7. Seals need to be seated — dry fire Stapler	
2	Driving blade retracts slowly	1. Low air pressure	Turn up air pressure to 80-110 psi max
		2. Lack of lubrication	Manually lubricate through male air inlet fitting
		3. Air supply restricted by small orifice	Use 1/4" minimum diameter air fittings
		4. U-Cup Lip Seals installed upside down	Replace all seals (Seal Kit A-5)
		5. Excessive dirt inside nailer	Disassemble, clean and lubricate
3	Staple is not countersunk	1. Low air pressure	Turn up air pressure to 80-110 psi max
		2. Broken Driving Blade	Replace Driving Blade (15)
		3. Stapler hit hard surface	Move from obstruction
		4. Driving blade jam nut came loose	Retighten or replace jam nut (22)
		5. Worn out gate	Replace gate (28)
4	Stapler leaks air	1. Air supply fittings loose	Tighten all air line fitting connections
		2. Dry wall dust in Stapler	Rebuild Stapler
		3. Excess air pressure blew out seals	Check air supply for 110 psi maximum—replace all seals
		4. Plunger screws loose	Tighten 3 plunger screws (8)
		5. Cracked or damaged body	Replace body (1)
		6. Seals worn out	Replace all seals (Seal Kit A-5)
		7. Seals need to be seated	Dry fire Stapler
5	Bottom of stapler cracked off	1. Operated without rubber bumper installed	Replace damaged parts
		2. Excessive air pressure used	Replace damaged parts
6	Staples jam in nailer	1. Not using Powerstapler™ Staples	Use Powerstapler™ Staples only (2", 1-3/4", 1-1/2" Lengths)
		2. Continued use after a short hit	Clear staple immediately after short hit
		3. Staple pusher damaged or spring broken	Replace staple pusher assembly (A-10)
		4. Staple channel loose	Tighten staple channel retaining screws (34, 41)
		5. Bent staple stuck in staple guide	Disassemble and clear out bent staple
		6. Hit another set staple or hard object	Move from obstruction
		7. Stapler gate worn out	Replace staple gate (28)
7	Plunger locked up—won't move or fire	1. Lack of lubrication	Manually lubricate through male air inlet fitting

POWERSTAPLE DEPTH CHART

This chart will assist you in determining the proper length of PowerStaple® to use for various thicknesses of flooring. Approximate vertical penetration of the PowerStaple under the hardwood floor is shown for each application. This is only a guide. Results should be tested in the field before proceeding.

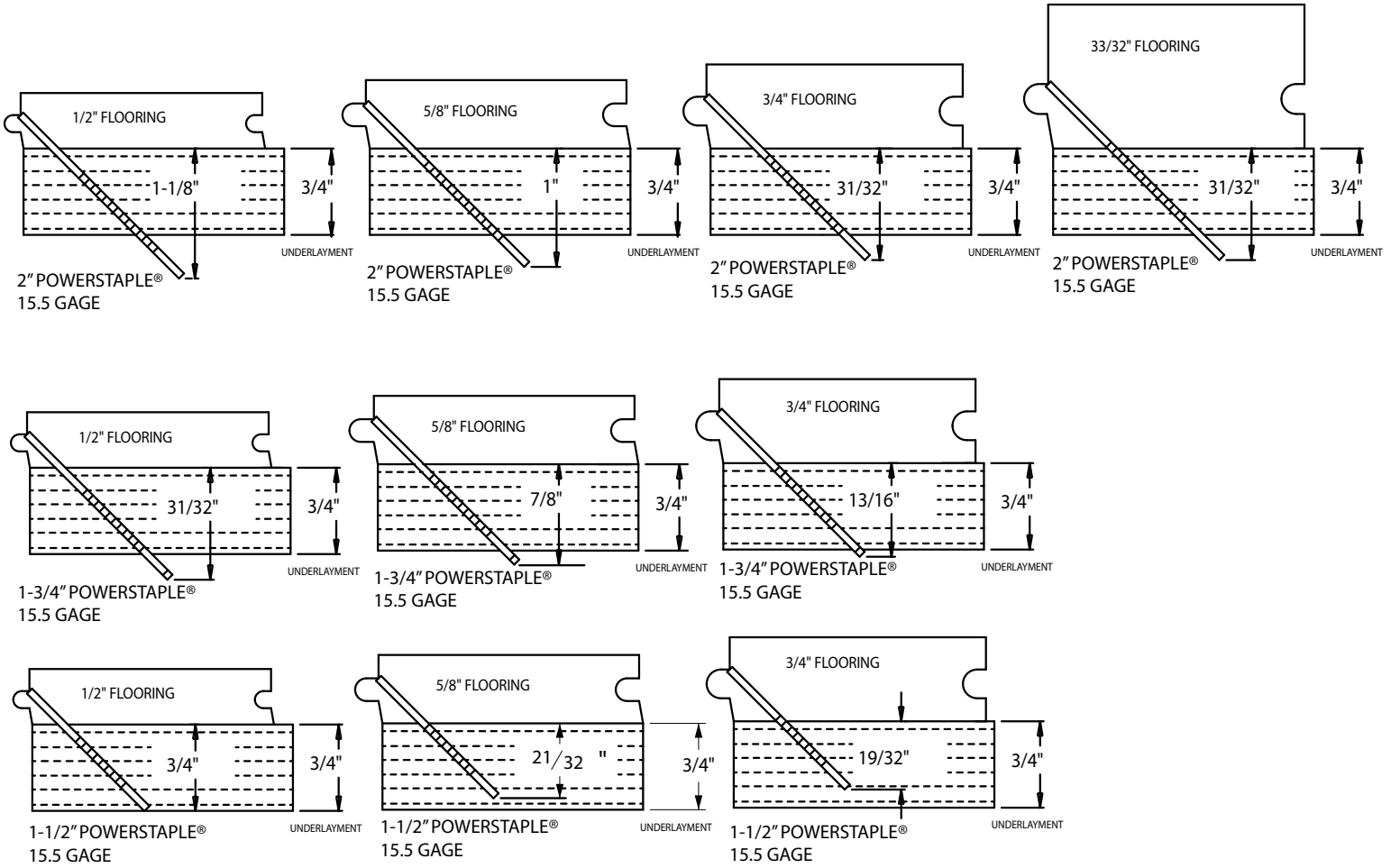

Featured Accessory Products

Powerjack® Model 500

Truly a Tinker's TOOL, the POWERJACK Model 500 is designed to push or pull flooring strips into place and hold them tightly. The PowerJack Model 500 self adjusts from 5/16" to 3/4" thickness flooring. It can be used to either push or pull wood flooring strips into place and ratchets tightly for hands free operation. The base of the PowerJack 500 has mounting holes for mid-floor use. Simply screw nail the PowerJack 500 to your sub floor -in front of your flooring strips -and ratchet the flooring strips tight. Also great for under cabinet and kick plate installation.

Part number: PJ500

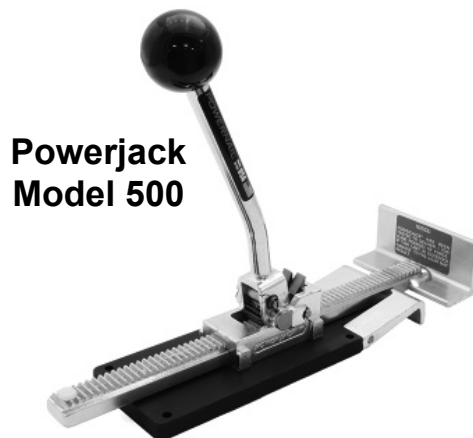

**Powerjack
Model 500**

The PowerPalm™

"The PowerPalm is the industries best solution to blind nailing close to the wall. Saves both, time and money!"

Pressure activated...simply press down, and let the tool do the work. The Power Palm will allow blind nailing closer to the wall and reduce the amount of face nailing. "Blind nail, top nail...tight spots and corners, the PowerPalm gets them all!" Featuring 360 degree swivel tip for fitting awkward or tight spaces. Magnetic cleat holder keeps nail in position. Uses both 16 gage and 18 gage Powercleats—Use the same fastener throughout your install! **Part number: PALM001**



*Closest you
can get to
the wall!*

Pneumatic PowerPalm™

15.5 Gauge PowerStaples™

Now you can get flooring staples with the strength and holding power you need to build a floor you can depend on. The Carbon Steel Powerstaples are designed for use with the Tongue and Groove PowerStapler 445FS, but can be used with all 15-15.5 gauge 1/2" crown flooring PowerStaplers.

Length	Qty	Part No
2"	7.7M	PS-20077
2"	6M	PS-2006
2"	5M	PS-2005
1-3/4"	5M	PS-1755
1-1/2"	6M	PS-1506
1-1/2"	5M	PS-1505



Visit www.Powernail.com

- Dealer Locator
- Rental Locator
- Parts Store
- Product Information
- Repair Tech Videos
- Cool Tools Cleat Calculator
- Cleat Depth Chart
- Training Schools

POWERNAIL® Warranty Registration

Register your warranty on the web and you will automatically be entered to win a **FREE!!! PowerPalm™**.



Scan this code with your phone to be taken to our warranty registration form

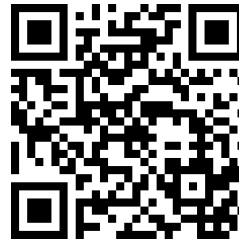

Register at <https://www.powernail.com/warranty-registration/>

POWERNAIL COMPANY, INC.
1300 Rose Road, Lake Zurich, IL 60047 US
Phone: 1-800-323-1653 OR 847-847-3000
www.powernail.com