

POWERNAIL® CO.

1300 Rose Road, Lake Zurich, IL 60047

Phone: 1-800-323-1653

Website: www.powernail.com

Operation and Maintenance Manual

MODEL 50M FLEX MANUAL POWERNAILER® FOR TONGUE AND GROOVE FLOORING 3/8" TO 5/8"



50M FLEX with Adjustable Foot

WARNING

Read this manual before you use this Nailer. Follow all safety warnings and instructions. If you are uncertain about the operation of the Nailer, call us directly at 1-800-323-1653 for assistance or contact the closest Powernail Dealer for help. Please retain this information for future reference.

TO PREVENT ACCIDENTAL INJURIES:

Always wear approved front and side **EYE PROTECTION** when operating this Nailer. Others in the work area should also wear front and side **EYE PROTECTION**. Eye protection will help guard against flying nails and debris, which could cause severe eye injury.

EAR PROTECTION may be required to prevent hearing damage when there are high noise levels in the work area.

DO NOT USE THE METAL END OF THE MALLET TO STRIKE THE PLUNGER, use the rubber capped end only.

Never place any part of the body in the discharge path of the Nailer.

DESCRIPTION

The Model 50M FLEX Powernailer® is the latest model designed to bring Powernail quality to a manual nailer. The Powernailer® Model 50M—designed for use with only 1", 1-1/4", 1-1/2" and 1-3/4" (18 gage) Powercleats® nails—provides several distinct advantages.

The Model 50M can nail down 3/8", 1/2", 5/8" and some exotic 3/4" tongue and groove hardwood flooring using the Powernails adjustable FLEX foot. For a superior manual Nailer, look to the company that has been the industry's quality leader for over 50 years, **POWERNAIL® COMPANY, INC.**

OPERATION

TOOL OPERATION

- 1 Adjust the FLEX foot to a sample of your flooring (see FLEX Foot Adjustment).
- 2 Make sure flooring strips are together tightly
- 4 Place nailer on tongued edge of flooring
- 5 Strike the plunger with rubber end of the mallet
- 6 The nailer will drive and set the nail at the correct 45 degree angle

LOADING CLEATS

- 1 Slide a clip of nails into the end of the nail channel feed slot.
- 2 Pull back the black nail pusher past the nails and let go.
- 3 Tension is now applied to the nails for use.

UNLOADING THE NAILER

- 1 Pull back on the black nail pusher knob and hold.
- 2 Tilt nailer back until nails slide out of nail channel.

WARNING

Do not use any nails other than Powernail Powercleats® (18 gage) nails, which are specifically designed for use in the Model 50M Powernailer. Powercleats® (18 gage) nails are available in 1", 1-1/4", 1-1/2" or 1-3/4" lengths to accommodate 3/8", 1/2", 5/8" and some exotic 3/4" tongue and groove hardwood flooring.

FLEX Foot Adjustment:

Wood varies from one manufacturer to the next. The different wood profiles may be due to height and length of the flooring tongue and whether or not there is a nail pocket.

First, loosen the two hex bolts under the FLEX foot with the Allen Wrench supplied with the nailer. (Figure 1.)

Next, set the nailer on a sample of your flooring (see Figure 2).

Use the adjustment lever at the back of the nailer foot to raise or lower the nailer to the wood.

Match the Adapter Foot Locating Ear so that it is pointing into the 90° angle created by the tongue and the top of the wood (see Figure 3).

For wood with a nail pocket, line up the Locating Ear so at the top of the nail pocket.

When the adjustment lever is in the correct position for your wood sample, tighten the two hex bolts to lock the FLEX foot into place.

Always check your adjustment with a sample to ensure the nail is driving into the nail pocket

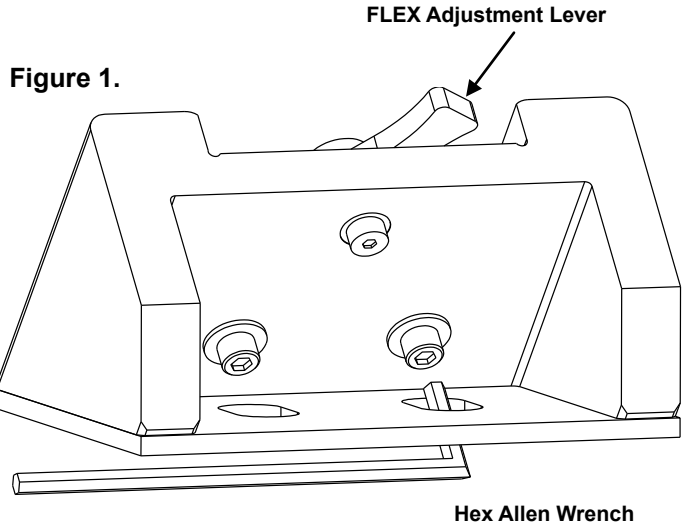

1. Loosen 2 hex screws.
2. Raise or lower the FLEX to your wood sample.
3. Match the Locating Ear to the nail pocket.
4. Tighten 2 hex screws.
5. Test wood sample with new adjustment.

Figure 2.

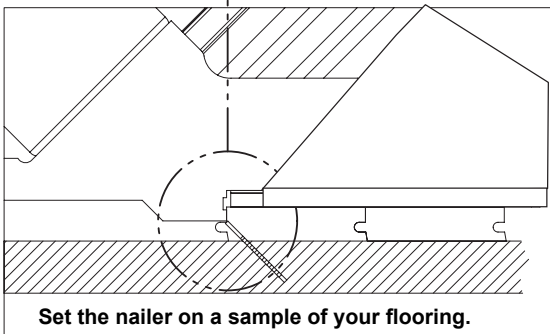
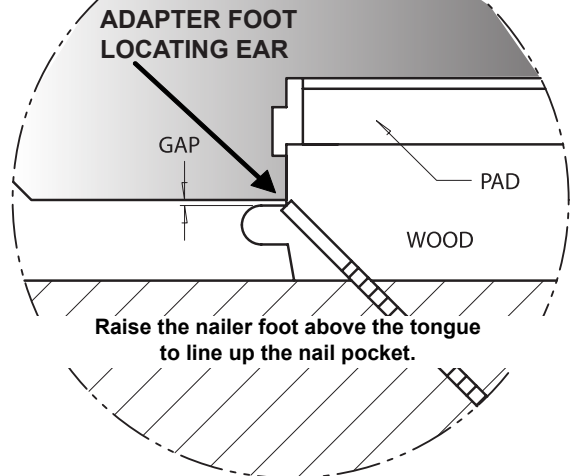

Figure 3.



Model 50M FLEX Parts List

ITEM #	PART NO.	DESCRIPTION	Qty Req
1	08-50M-00-630	BODY ASSEMBLY	1
2	08-50M-00-150	FOOT	1
3	08-50M-00-380	DRIVING BLADE	1
4	07-50M-00-370	PLUNGER	1
5	08-250-00-450	PLUNGER SPRING	1
6	08-250-00-410	PLUNGER SPRING PIN	1
7	08-250-00-640	ROLLER PIN	1
8	08-250-00-740	1/4-20 X 1-3/4 S.H.C.S. (FOOT)	4
9	08-250-00-750	1/4-20 FLANGE NUT	4
10	09-200-3034	PUSHER SPRING	1
11	09-200-3057	#10-32 X 1/2 F.H.C.S. SLOTTED (PAD)	4
12	09-200-3035	SPOOL SET	1
13	09-50P-3005	ADAPTER FOOT	1
14	09-50P-3008	CHANNEL	1
15	09-50P-3042	GATE	1
16	09-50P-3017	GATE PLATE	1
17	09-50P-3038	SHIM	4
18	09-50P-3037	.200 THICK UHMW PLASTIC PAD	1
19	09-445-29745	#10-32 X 1-1/4 S.H.C.S.(KNOB)	1
20	09-445-29754	#10-32 X 1/2 S.H.C.S. (FOOT)	4
21	09-445-29822	#10-32 x 3/4" S.H.C.S. (GATE)	3
22	09-445-29741	1/8 X 5/8 ROLL PIN	2
23	09-445-29735	NAIL PUSHER	1
24	09-445-29735.2	KNOB	1
25	09-445-29756	STANDOFF	2
26	09-445-29750	#8-32 X 1-1/2 F.H.C.S.	2
27	09-445-29751	#8-32 LOCKNUT	2
28	08-45-00-580	BLADE RETAINER	1
29	08-45-00-610	COTTER PIN	1
30	09-50P-3040	CHANNEL PLATE	1
31	09-50P-3041	#6-32 X 3/8 B.H.C.S	2
54	09-445-29758	1/4 Split Ring Lock Washer (Foot)	4
70	09-50P-3070	FLEX Foot	1
71	09-50P-3071	FLEX Foot Bracket	1
72	09-50P-3072	FLEX Foot Cam	1
73	09-50P-3073	FLEX Foot Cam Plate	1
74	09-50P-3074	FLEX Foot Pad	1
75	09-50P-3075	SHCS 1/4-28 x 1.25"	2
76	09-50P-3076	Washer .281 IDx.62 ODx.051" T	2
77	09-50P-3077	BHCS #10-32 x .50"	2
78	09-50P-3078	1/4 SH DIA x .50" SH. Bolt	1
79	09-50P-3079	Belleville Disc Spring	1
80	09-50P-3080	FLEX Foot Wrench Clip	1
93	09-50P-3090	FLEX Adapter Foot	1

50M FLEX Schematic

For this and other Powernailer schematics, please visit the
Powernail Parts Store at <http://www.powernail.com>

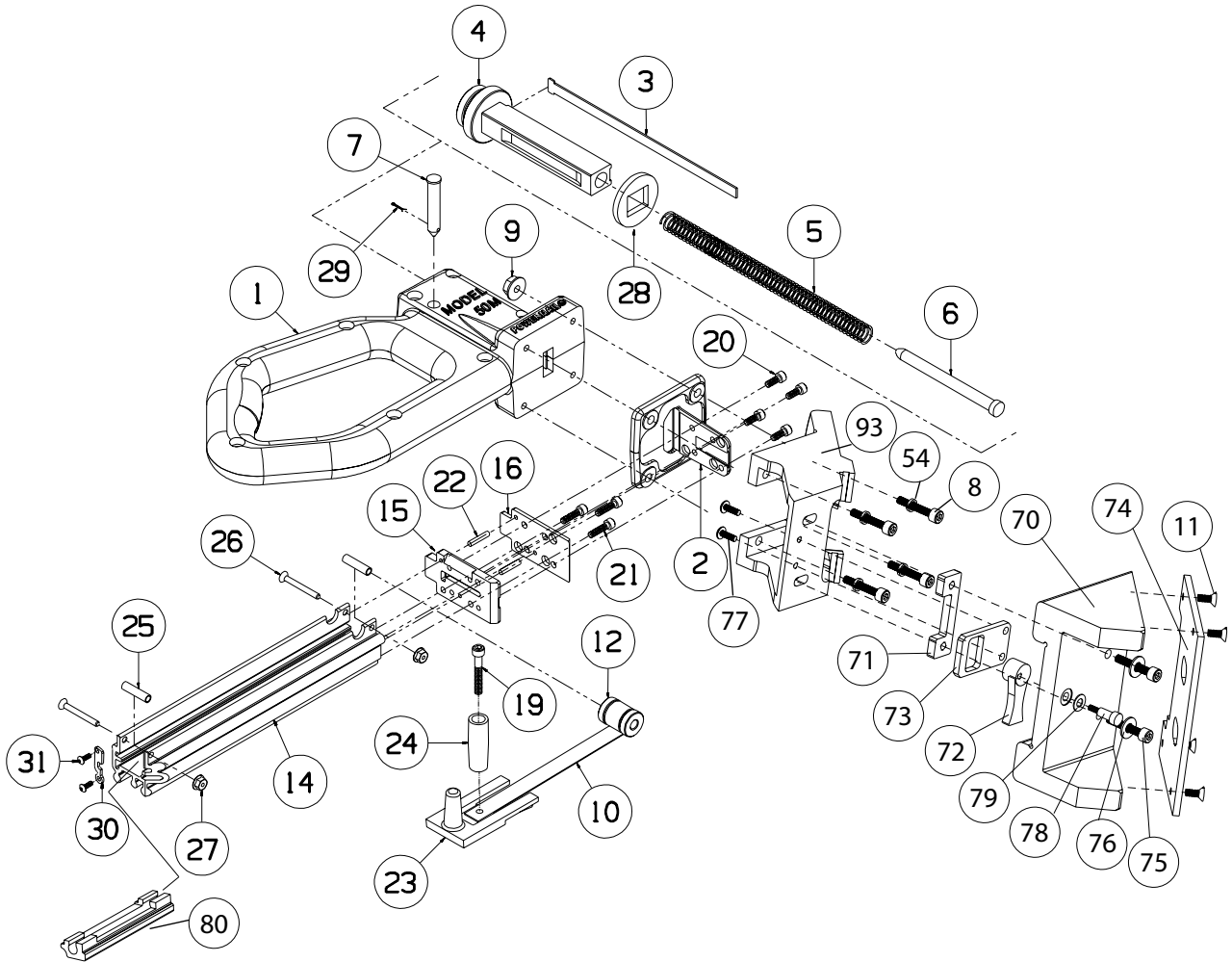

Model 50M FLEX Assemblies, Kits & Accessories

ITEM #	PART NO.	DESCRIPTION	Qty Req
A-1	AW-200	ALLEN WRENCH SET	1
A-2	09-50M-3065A	CHANNEL ASSEMBLY	1
A-3	09-200-3063A	NAIL PUSHER ASSEMBLY	1
A-4	08-50M-TU-KIT	MODEL 50M TUNE UP KIT	1
A-5	08-50M-OVH-KIT	MODEL 50M OVERHAUL KIT	1
A-6	09-AW-FLEX	FLEX 3/16" Allen Wrench	1

WARNING Never hit the Nailer with excessive force or with the metal end of the mallet, this will damage the nailer.

Before each use, check all screws to be sure they are tight. Shock and vibration can loosen screws. Do not over tighten any screw.

TO CLEAR A NAIL JAM:

1. It helps to tap the Driving Blade back to the retracted position before trying to remove a jammed nail. A spare Driving Blade works best for this.
2. Try to pull the jammed nail out of the gate with a pair of long nose pliers. If this does not work remove the four (4) cap screws holding the Foot, Gate and Nail Channel Assembly together.
3. Separate the Foot and Gate with a screw driver just enough to clear out the jammed nail.
4. Put thread locking compound on all screws and reassemble the components.

POWERCLEATS LENGTH DETERMINATION CHART

This chart will assist you in determining the proper length of Powercleats to use for various thicknesses of flooring. Approximate vertical penetration of the Powercleat under the hardwood floor is shown for each application. This is only a guide. Results should be tested in the field before proceeding.

1-3/4" 18 GA POWERCLEATS®

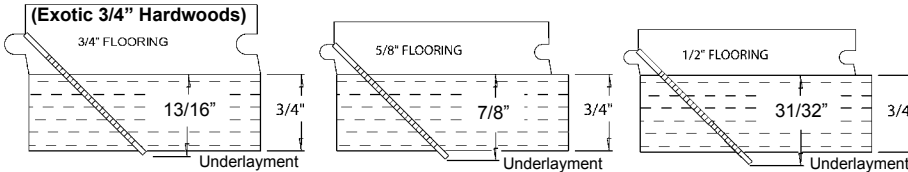

1-1/2" 18 GA POWERCLEATS®

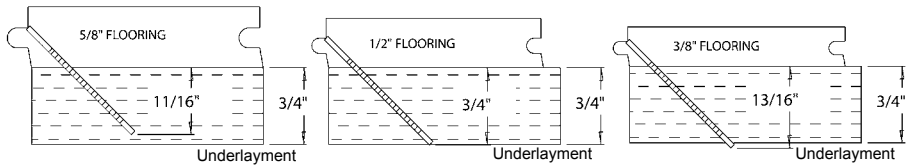

1-1/4" 18 GA POWERCLEATS®

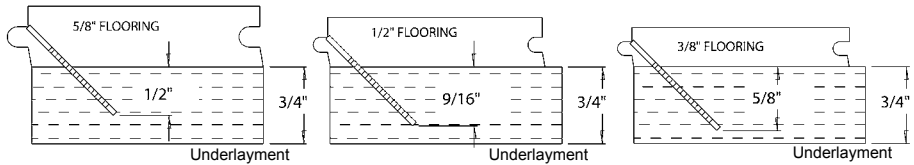

1" 18 GA POWERCLEATS®

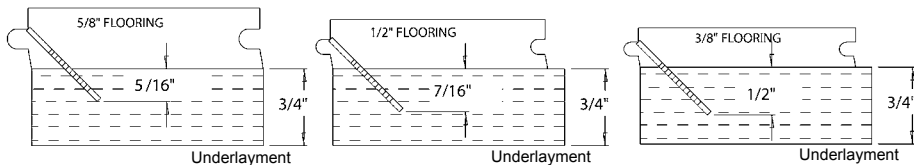

Visit www.Powernail.com on the web!

- Dealer Locator
- Rental Locator
- Parts Store
- Product Information
- Repair Tech Videos
- Cool Tools Cleat Calculator
- Cleat Depth Chart
- Training Schools

Featured Accessory Products

Powerjack® Model 100

Truly a Tinker's TOOL the Powernail Powerjack® allows crooked strip to be put into place (tongue and groove) and then firmly nailed. Utilizing a unique rack assembly the Powerjack is placed against a Stationary Object, such as a wall, the lip end is then placed over the crooked strip groove side. By working the lever the crooked plank is drawn into the existing flooring. A Powernail Nailer then nails the board into place. To release the Powerjack® simply push the handle fully forward. Part number: 06-99650

Powerjack
Model 100



Powernailer TOOLBOX

NEW! The Powernail Toolbox is a large plastic case designed for long and short handled pneumatic nailers including Models 445, 50P and Model 200. Tough and durable plus room for extra tools.

Part number: 06-99205.



TOOLBOX for pneumatics

Cleat Pouch

Great gift idea for the contractor who has everything! All Leather Cleat Pouch for carrying sticks of cleats. Great for use on-the-job when installing hardwood floors. Quicker reloads keep you running smoothly. Magnetic button cover closes securely while still allowing easy access to cleats for quick reload. Sturdy belt loop on back keeps pouch firmly in place. Pouch is thin, compact and stays snug to the waist.

Part number: 06-99910



Leather Cleat Pouch

POWERNAIL® USA
THE LEADER IN FASTENING TECHNOLOGY 