

POWERSTAPLER MODEL 445 FS

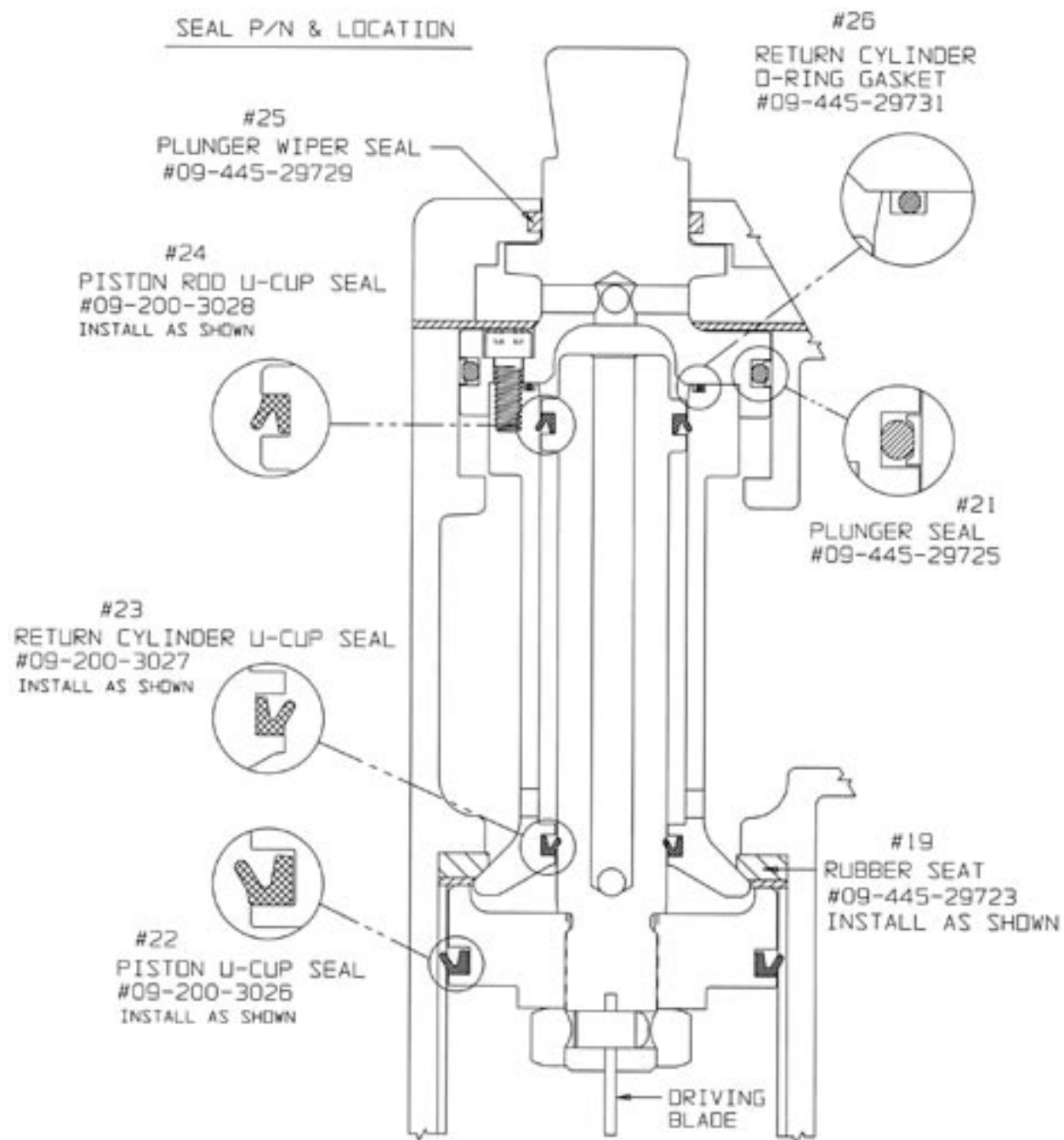

POWERSTAPLER MODEL 445 FS TROUBLE SHOOTING CHART

NO.	PROBLEM	POSSIBLE CAUSE	SOLUTION
I	Driving blade does not retract	1 Zero or low air pressure	Check air supply for 90 psi minimum to 120 psi maximum
		2 Lack of lubrication	Manually lubricate through male air inlet fitting
		3 Excessive dirt inside Stapler	Disassemble and clean
		4 Bent driving blade	Replace driving blade
		5 Seals worn out	Replace all seals
		6 U-Cup Lip Seals installed upside down	
		7 Seals need to be seated – dry fire Stapler	
II	Driving blade retracts slowly	1 Low air pressure	Turn up air pressure to 90-120 psi max
		2 Air supply restricted by small orifice(s)	Use 1/4" min. diameter air fittings
		3 Lack of lubrication	Manually lubricate through male air inlet fitting
		4 Excessive dirt inside Stapler	Disassemble and clean
		5 U-Cup Lip Seals installed upside down	
III	Staple is not countersunk	1 Low air pressure	Turn up air pressure to 90-120 psi max
		2 Broken driving blade	Replace driving blade
		3 Stapler hit hard surface	Move from obstruction
		4 Driving blade jam nut came loose	Retighten or replace jam nut with a locking compound
		5 Worn out gate	Replace gate
IV	Stapler leaks air	1 Air supply fittings loose	Tighten all air line fitting connections
		2 Dry wall dust in nailer	Rebuild Stapler
		3 Excess air pressure blew out seals	Check air supply for 120 psi maximum - replace all seals
		4 Plunger screws loose	Tighten 3 plunger screws
		5 Cracked or damaged body	Replace body
		6 Seals worn out	Replace all seals
		7 Seals need to be seated – dry fire Stapler	
V	Bottom of Stapler cracked off	1 Operated without rubber bumper installed	Replace damaged parts
VI	Staples jam in Stapler	2 Excessive air pressure used	Replace damaged parts
		1 Not using Powerstapler® Staplers	Use Powerstapler® Staplers only
		2 Wrong Powerstapler® Stapler used	Use 2", 1-3/4" or 1-1/2" only
		3 Continued use after a short hit	Clear Stapler immediately after short hit
		4 Staple pusher damaged or spring broken	Replace Stapler pusher assembly
		5 Staple channel loose	Tighten Stapler channel retaining screws
		6 Bent Staple stuck in staple guide	Disassemble and clear out bent Staple
		7 Hit another set Stapler or hard object	Move from obstruction
8 Stapler gate worn out	Replace Staple gate		
VII	Plunger locked up — won't move or fire	1 Plunger & safety yoke reassembled incorrectly	Move safety yoke into top groove on plunger
		2 Safety trigger not being depressed—Stapler body being used to rack the wood	Replace damaged plunger, safety yoke and plunger seal
		3 Lack of lubrication	Manually lubricate through male air inlet fitting

POWERNAIL® CO.

1300 Rose Road, Lake Zurich, IL 60047
 phone: 1-800-323-1653
 website: www.powernail.com

Operation and Maintenance Manual

MODEL 445 FS PNEUMATIC POWERSTAPLER™



WARNING

Read this manual before you use this stapler. Follow all safety warnings and instructions. Do not attempt any disassembly or repairs while the air line is connected. Always disconnect the air line first. Do not use excessive unregulated air pressure. If you are

uncertain about the operation of the Stapler, call us directly at 1-800-323-1653 for assistance or contact the closest Powernail® Dealer for help. Please retain this information for future reference.

TO PREVENT ACCIDENTAL INJURIES

Always wear approved front and side **EYE PROTECTION** when operating this Stapler. Others in the work area should also wear front and side **EYE PROTECTION**. Eye protection will help guard against flying nails and debris, which could cause severe eye injury.

EAR PROTECTION may be required to prevent hearing damage when there are high noise levels in the work area.

Always **DISCONNECT THE AIR SUPPLY** before making any adjustments, repairing, clearing jams or when the Stapler is not in use.

Never attach the female end of a quick disconnect to the Stapler. This will trap air inside the Stapler and permit it to be discharged. Only the unrestricted male connection should be attached to the Stapler.

Use only regulated compressed air, do not use bottled gases of any kind to power this Stapler. Normal air pressure should not exceed 120 psi or damage to the Stapler and seals may occur. Excess air pressure can cause the Stapler to explode.

DESCRIPTION

The PowerStapler® Model 445 FS Mallet Actuated Pneumatic Stapler is the latest model designed to bring Powernail quality to a pneumatic Stapler. For those looking for the ease-of-use of a pneumatic tool, the PowerStapler Model 445 FS—designed for use with 1-1/2", 1-3/4" and 2" Powerstaples® staples—provides several distinct advantages. Like our Model 45, the Model 445 FS can nail down 1/2", 3/4" and 33/32" tongue and groove hardwood flooring through the use of easy-to-change, no-mar

WARNING Whenever air is connected to the Stapler keep body parts away from the Stapler discharge path. Disconnect the air line before making adjustments or repairs on the Stapler. Connect air to unloaded Stapler only to prevent accidental discharge.

Rack the flooring into place with the rubber end of the mallet supplied with the Stapler.

Place the Stapler Adapter Foot on the tongued edge of the flooring strip to be stapled. Be sure the Adapter Foot is pressed tightly against the edge of the flooring strip above the tongue. Be sure flooring strips are racked tightly. Pull the Safety Trigger

THE TRIGGER IS A SAFETY DEVICE and should only be pulled when the Stapler is in proper position on the work surface and before the plunger is struck with the mallet. Do not tie or tape down the safety trigger as the Stapler could discharge if dropped on the plunger. The Stapler will not fire unless the trigger is pulled before the mallet blow.

Do not use the trigger safety as a lock-up for the plunger then rack the wood using the locked-up Stapler body. It will severely damage the mechanism and the Stapler. Use the mallet to rack the wood strip, not the Stapler.

DO NOT USE THE METAL END OF THE MALLET TO STRIKE THE PLUNGER, use the rubber capped end only.

Never place any part of the body in the discharge path of the Stapler when air is connected to the Stapler. Always connect air hose to unloaded Stapler to prevent any accidental discharge from occurring.

Never leave the Stapler unattended while it is connected to an air supply.

adapter plates. To use the Model 445 FS, simply snug up the flooring with the rubber mallet, pull the safety trigger and tap the plunger with the rubber capped mallet end and let the Stapler drive and set the staple at the correct 45 degree angle. For a superior pneumatic Stapler, look to the company that has been the industry's quality leader for over 50 years, **POWERNAIL® COMPANY, INCORPORATED**.

and tap the Stapler Plunger Rubber Cap with the rubber capped end of the mallet to discharge the Stapler.

WARNING It is not necessary to hit the Stapler hard to activate it. Never hit the Stapler with excessive force or with the metal end of the mallet, this will damage the Stapler.

Never use the Safety Trigger interlock to lock up the plunger and rack the wood with blows to the Stapler body. This will severely damage the safety mechanism and Stapler. This abuse and damage is not covered by the warranty.

MODEL 445 FS PARTS LIST

ITEM	PART NO.	DESCRIPTION	QTY. REQ'D.	KEY REF. NO.
1.	09-445-29320	BODY	1	F
2.	09-445-29321	CAP	1	S
3.	09-445-29703	HANDLE, LONG	1	A
4.	09-445-297031	HANDLE, SHORT	1	A
5.	09-445-29704	HANDLE HALF	1	A
6.	09-445-29705	ADAPTER FOOT	1	S
7.	09-445-29706	FOOT	1	S/A
8.	09-445-29707	SAFETY YOKE	1	S
9.	09-445-29710	PISTON ROD	1	S/A
10.	09-445-29711	PISTON	1	S/A
11.	09-445-29830	RETURN CYLINDER	1	S/A
12.	09-445-29831	PLUNGER	1	S
13.	09-445-29715	CYLINDER SLEEVE	1	S
14.	09-445-29303	DRIVING BLADE	1	S/A
15.	09-445-29719	BODY PLATE	1	S
16.	09-445-29720	TRIGGER	1	S/A
17.	09-445-29721	SUPPORT RING	1	S
18.	09-445-29722	RUBBER CAP	1	S
19.	09-445-29723	RUBBER SEAT	1	S/A/K
20.	09-445-29724	RUBBER BUMPER	1	S
21.	09-445-29725	PLUNGER SEAL SET	1	S/A/K
22.	09-200-3026	PISTON U-CUP SEAL	1	S/A/K
23.	09-200-3027	RETURN CYLINDER U-CUP SEAL	1	S/A/K
24.	09-200-3028	PISTON ROD U-CUP SEAL	1	S/A/K
25.	09-445-29729	PLUNGER WIPER SEAL	1	S/A/K
26.	09-445-29731	RETURN CYLINDER O-RING GASKET	1	S/A/K
27.	09-445-29732	TRIGGER CABLE, LONG	1	S/A
28.	09-445-297321	TRIGGER CABLE, SHORT	1	S/A
29.	09-445-29733	SAFETY YOKE SPRINGS	2	S
30.	09-445-29326	STAPLE PUSHER SPRING	1	S/A
31.	09-445-29327	#8-32 X 5/16 B.H.C.S. (CHANNEL)	1	S/A
32.	09-445-29328	#8-32 X 1/4 F.H.C.S. (CHANNEL)	1	S/A
33.	09-445-29329	STEEL STAPLE PUSHER	1	S/A
34.	09-445-29736	1/2" ADAPTER PAD (ACCESSORY)	1	S
35.	09-445-29737	5/8" ADAPTER PAD (STANDARD)	1	S
36.	09-445-29738	3/4" ADAPTER PAD (STANDARD)	1	S/A
37.	09-445-29739	1/4 X 3/4 DOWEL PIN (TRIGGER)	1	S
38.	09-445-29740	1/4 X 1/2 DOWEL PIN (DRIVING BLADE)	1	S
39.	09-445-29815	HANDLE, EXTRA LONG	1	A
40.	09-445-29816	TRIGGER CABLE, EXTRA LONG	1	S/A
41.	09-445-29331	#10-32 X 1-1/2 S.H.C.S. (STANDOFF)	1	S/A
42.	09-445-29325	TWO PART CHANNEL W/ TWO B.H.C.S.	1	S/A
43.	09-445-29305	GATE PLATE	1	S/A
44.	09-445-29330	GATE	1	S/A
45.	09-445-29756	1/4 X 1 STANDOFF SPACER (CHANNEL)	1	S/A
46.	09-445-29742	1/4-20 X 7/8 S.H.C.S. (XL HANDLE HALF)	1	S
47.	09-445-29743	1/4-20 X 1 S.H.C.S. (CAP)	4	S
48.	09-445-29744	1/4-20 X 3/4 S.H.C.S. (HANDLE)	6	S
49.	09-445-29747	1/4-20 X 1-1/4 S.H.C.S. (FOOT)	4	S

MODEL 445 FS PARTS LIST

ITEM	PART NO.	DESCRIPTION	QTY. REQ'D.	KEY REF. NO.
50.	09-445-29748	5/8-18 JAM NUT (DRIVING BLADE)	1	S
51.	09-445-29317	#10-32 X 3/4 S.H.C.S. (FOOT)	4	S
52.	09-445-29832	#10-32 X 3/4 S.H.C.S. (PLUNGER)	3	S
53.	09-445-29757	1/4-20 X 1/2 F.H.C.S. (PAD)	3	S
54.	09-445-29758	1/4-20 SPLIT RING LOCK WASHER	4	S
55.	09-445-29759	3/8 NPT 45 DEGREE STREET ELBOW	1	S
56.	09-445-29760	#8-32 X 3/8 B.H.C.S. (CABLE)	1	S
57.	09-445-29836	#10-32 X 3/8 S.H.C.S. (GATE)	2	S
58.	09-445-29313	#6-32 X 3/8 F.H.C.S. (GATE)	2	S
59.	09-445-29819	.030 PLASTIC SHIM	2	S
60.	09-445-29738.1	22MM ADAPTER PAD (ACCESSORY)	1	A

ASSEMBLIES, KITS & ACCESSORIES

ITEM	PART NO.	DESCRIPTION	QTY. REQ'D.	KEY REF. NO.
A-1	09-445-29736	1/2" ADAPTER PAD	1	
A-2	09-445-29737	5/8" ADAPTER PAD	1	
A-3	09-445-29738	3/4" ADAPTER PAD	1	
A-4	09-445-29757A	8 OZ. AIR TOOL OIL	1	
A-5	09-200-3058A	SEAL KIT (1 EACH OF ALL SEALS)	1	
A-6	09-445-29759A	LONG HANDLE ASSEMBLY	1	
A-7	09-445-29760A	SHORT HANDLE ASSEMBLY	1	
A-8	09-445-29365A	STAPLE CHANNEL ASSEMBLY	1	
A-9	09-445-29366A	STAPLE PUSHER ASSEMBLY	1	
A-10	09-445-29364A	DRIVING BLADE ASSEMBLY W/SEAT	1	
A-11	09-445-29765	3/8 X 50FT. VINYL HOSE W/FITTINGS	1	
A-12	09-445-29766	3/8 M&F COUPLING SET	1	
A-13	09-445-29767	HOSE CLAMP	1	
A-14	09-445-29768	BOX WRENCH	2	
A-15	09-445-29824A	EXTRA LONG HANDLE ASSEMBLY	1	
A-16	09-445-5421	AIR GAUGE	1	
A-17	09-445-5421R	FILTER/REGULATOR GAUGE	1	
A-19	AW-445	ALLEN WRENCH SET	1	

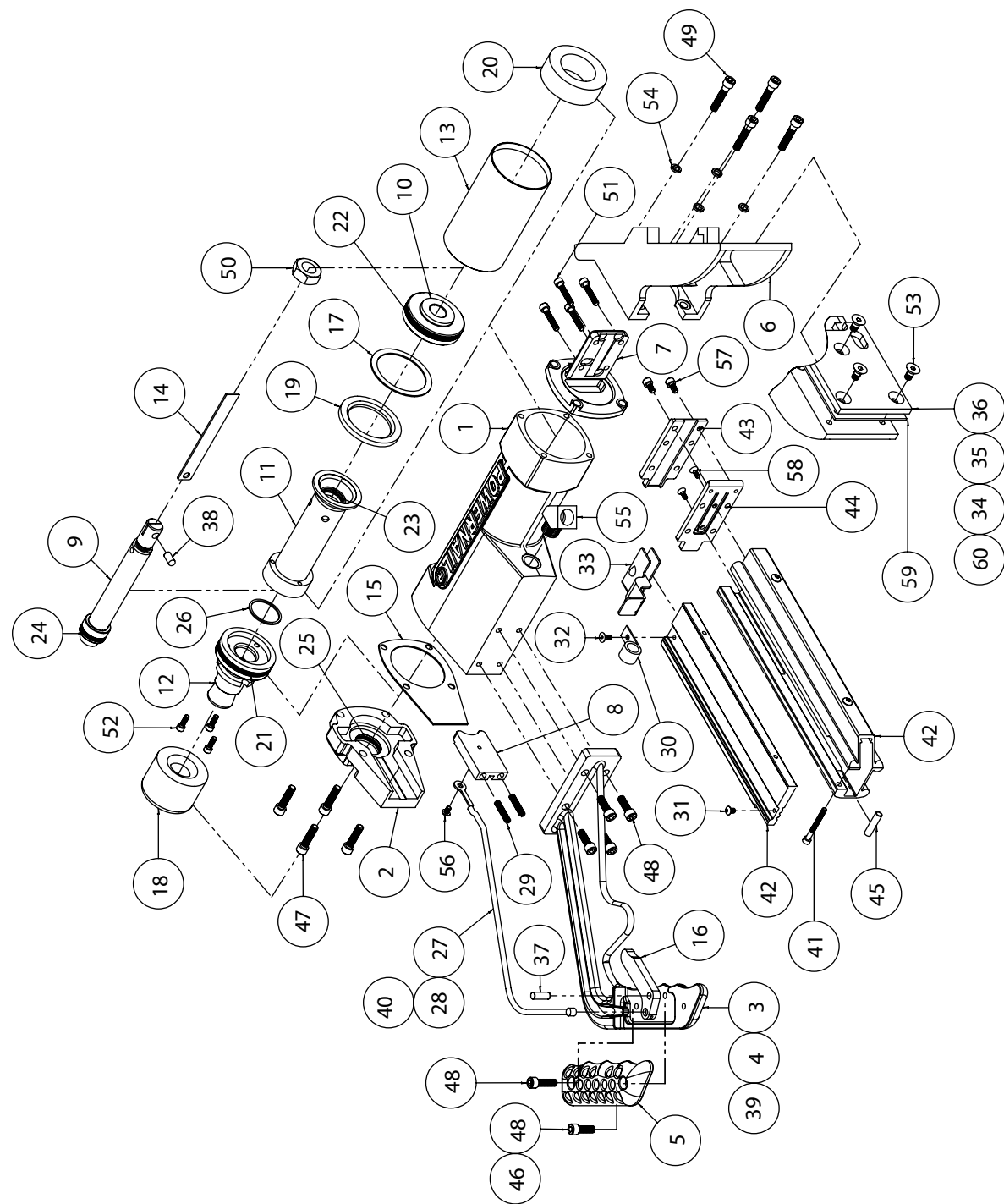

Before each use check all screws to be sure they are tight. Shock and vibration can loosen screws. Do not over tighten any screw.

AIR SUPPLY:

The air must be clean and dry. Dirty and/or wet air will damage the Stapler. A combination filter-regulator-lubricator is required for proper Stapler performance and should be placed close to the Stapler per manufacturers' recommendations.

Drywall Dust:

- Using Pneumatic PowerStaplers in drywall dust conditions will dramatically decrease the life of the Stapler.
- Drywall dust is abrasive, when cycled through the Stapler it will cause excessive wear.

Fill the lubricator with a high-quality Air Tool Oil. Adjust the lubricator to the manufacturers' recommendations. Do not over oil the Stapler, as excess oil will be discharged with the spent air and could stain the wood flooring, walls or furnishings. **We will not be responsible for oil stains.**

WARNING

Detergent oil is not recommended and may damage the seals. Consult the filter-regulator-lubricator manufacturer's recommendations for proper operation, settings and unit maintenance.

The air source must continuously deliver 100 to 120 psi and 3-1/2 cubic feet of air per minute to operate the Stapler. Connect a 1/4" minimum internal diameter and clean air hose to the Stapler. Be sure the air regulator is set at 90 psi. If the nail is not countersunk below the surface of the wood, turn up the air pressure, but not over 120 psi.

Check for air supply leaks that waste air and starve the Stapler of air thereby reducing its performance. There should be no orifice smaller than 1/4" in the air path between the Regulator and the Stapler.

LUBRICATION:

If you do not use an in-line lubricator, you must lubricate the Stapler manually. The frequency of lubrication is dependent upon the duty cycle of the Stapler. Continuous duty requires more frequent oiling than intermittent duty.

At least every eight (8) hours place two to four drops of Air Tool Oil, supplied with your Stapler, into the disconnected air line male connector attached to the Stapler.

WARNING

Do not over lubricate the Stapler, excess oil mist or drops will be vented with spent air when over lubricated. Excess oil could stain the wood flooring, walls or furnishings. Dry fire the Stapler, without nails, to purge excess oil, before you begin to nail down flooring. **We will not be responsible for oil stains.** Before storing the Stapler, lubricate and cycle the Stapler in insure internal parts are oil protected from corrosion.

TO LOAD MODEL 445 FS:

Pull back the steel staple pusher until it catches and locks in place on angle at rear end of center channel. Place up to two clips (about 100 staples) into top of channel slot and allow to slide down channel into place. Unlock steel pusher by pulling it back and up and over angle so it slides on center channel until it makes contact with staples.

TO LOAD MODEL 445 FS:

Disconnect air supply before unloading. To remove staples from staple channel, pull back steel staple pusher until it catches and locks in place on angle at rear end of the center channel. Tilt stapler back so that any remaining staples may slide back down the channel towards rear of stapler. Turn stapler over allowing staples to come out of slot on top of channel.

PARTS & SERVICE:

When ordering parts include the part number, part description, PowerStapler model and serial number. Be sure to state the quantity of the part(s) required. Contact your Powernail Dealer for the necessary parts.

WARNING

Never work on the Stapler if the air line is attached. Always disconnect the air line from the Stapler first.

Stapler DISASSEMBLY:

TO REPLACE RUBBER BUMPER (#20):

1. Disconnect the air supply
2. Remove the four (4) cap screws (#49) holding the Adapter Foot, Foot and Nail Channel assembly to the main Body (see illustration).
3. Pull the Rubber Bumper out of the cylinder bore. Replace the old Bumper if it shows signs of wear or it is split.
4. Reverse these steps to reassemble the Stapler. Be sure to align the Driving Blade with the slot in the Staple Channel Assembly while you reassemble the Stapler. **NEVER FIRE THE STAPLER WITHOUT THE RUBBER BUMPER INSTALLED, IT WILL SEVERELY DAMAGE THE STAPLER.**

TO REPLACE DRIVING BLADE (#14):

1. Disconnect the air supply
2. Remove the four socket head cap screws holding the Adapter Foot, Foot and Staple Channel Assembly to the body.
3. Remove the Rubber Bumper
4. Pull the Driving Blade with pliers until the Piston is fully extended outward towards the bottom of the cylinder.
5. Use the 15/16 inch box wrench supplied to unscrew the Driving Blade Jam Nut and remove it. Hold the Piston from turning while unscrewing the Jam Nut by holding the piston hex with the 1-1/8" box wrench supplied.

6. Push out the 1/4" diameter blade retaining Dowel Pin and remove the broken Driving Blade stub.
7. Install a new Driving Blade in the slot and replace the Dowel Pin. Screw on the retaining Jam Nut using the same tools. If the Jam Nut becomes worn and loose after frequent removals, it should be replaced.
8. Check the fit, there should be some sideways movement between the Driving Blade and the Jam Nut assembly. This is desirable and helps the blade to align itself with the mating parts.
9. Reassemble the components. Be sure to align the Driving Blade with the slot in the Adapter Foot Assembly.

SEAL REPLACEMENT:

There are 7 seals that may require replacement. We recommend that you have your POWERNAIL Dealer replace the Seals.

SEAL KIT:

You may choose to buy a Seal Replacement Kit and replace the seals yourself. It is good practice to replace all seals at one time regardless if only one seal needs replacement.

SEAL DESCRIPTION & NUMBER:

1. Rubber Seat (#19)
2. Plunger Seal Set (#21)
3. Piston U-Cup Lip Seal (#22)
4. Return Cylinder U-Cup Lip Seal (#23)
5. Piston Rod U-Cup Lip Seal (#24)
6. Plunger Wiper Seal (#25)
7. Return Cylinder O-Ring Gasket (#26)

To change Seals follow these procedures. Be sure the air line is disconnected from the Nailer first before making any repairs. Consult the illustration for the name and location of the following component parts.

DRIVING BLADE ASSEMBLY-REMOVAL:

1. Disconnect the air supply.
2. Remove Rubber Plunger Cap (#18).
3. Unscrew & remove Body Cap (#2).
4. Push Safety Yoke (#8) aside and unscrew the three 10-32 cap screws holding the Plunger (#12) to the Return Cylinder (#11).
5. Pull the Plunger up and out of the Nailer Body (#1) cavity.
6. Remove the Return Cylinder O-Ring Gasket (#26) located on the top of the Return Cylinder under the Plunger.
7. Turn the Stapler over and remove the four cap screws (#49), that fasten the Adapter Foot and Nail Channel Assembly to the Nailer Body and lift the Assembly off the Body.
8. Remove the Rubber Bumper (#20).
9. Pull the Driving Blade Assembly out of the Stapler Body by

pulling on the Driving Blade.

10. Hold the Piston Rod (#9) with an 11/16 socket over its hex end opposite the Piston. **Do not use pliers or a vise anywhere on the metal parts, they can damage the sealing surfaces.**
11. Use the supplied box wrenches to remove the 5/8-18 Jam Nut (#50). Remove the Dowel Pin (#38) and Driving Blade (#14).
12. Unscrew the Piston from the Piston Rod using the supplied box wrenches and separate the Piston, Piston Rod and Return Cylinder (#11).

TO REPLACE THE SEALS:

Rubber Seat (#19):

1. Remove the Cylinder Sleeve (#13). The Cylinder Sleeve should slide out of the Stapler Body when you pull out the Driving Blade Assembly.
2. Remove the metal Support Ring (#17) and Rubber Seat from inside the Stapler body. **Note that the chamfer on the inside of the Rubber Seat faces the BOTTOM of the Stapler**, do not reverse the direction of the chamfer when you replace the Rubber Seat.
3. Replace the Rubber Seat, Support Ring and Cylinder Sleeve. Be sure to re-install the steel Cylinder Sleeve with the chamfered inside edge facing the BOTTOM of the Stapler.

Plunger Seal Set (#21):

1. Remove the Teflon® Seal and its O-Ring expander from the groove using a bent paper clip or pick. Be sure not to scratch the inside walls of the seal groove with the wire hook.
2. Clean out the seal groove. Place a new O-Ring into the seal groove by stretching it over the Plunger body. Make sure the O-Ring is not twisted in the groove. Place a new Teflon® Seal Ring into the seal groove over the O-Ring.
3. Carefully push the Teflon® Seal Ring over the edge of the Plunger with your thumbs and into the groove. Do this as quickly as possible to reduce stretching of the Teflon® Seal Ring. **DO NOT OVER STRETCH THE TEFLON® SEAL RING!** Be sure the Teflon® Seal Ring is centered all around the seal groove and not twisted.
4. Wipe off the Seal surface with a clean rag and lubricate it generously with the supplied lubricant, O-Ring grease or petroleum jelly.

Piston U-Cup Lip Seal (#22):

1. Remove the old Piston U-Cup Lip Seal from the Piston using a bent paper clip or pick, being careful not to scratch the inside walls of the seal groove or the edge of the Piston with the wire hook.

2. Clean out the seal groove. Place a new U-Cup Lip Seal into the groove. Make sure the lips are not twisted in the groove and the lips face the top of the Stapler. See the sketch on page #9.
3. Carefully wipe off the U-Cup Lip Seal surface with a clean rag and lubricate it generously with the supplied lubricant, O-Ring grease or petroleum jelly.

Return Cylinder U-Cup Lip Seal (#23):

1. Use a bent paper clip or pick to remove the old U-Cup Lip Seal from the internal seal groove inside the Return Cylinder. Be careful not to scratch the inside walls of the seal groove with the wire hook.
2. Clean out the seal groove. Place a new U-Cup Lip Seal into the groove, be sure it is not twisted in the groove. Be sure the lips are facing the inside of the Return Cylinder as shown in the sketch on page #9.

WARNING

The U-Cup Lip Seals #23 and #24 look alike, but they are different, DO NOT mix them up.

3. Carefully wipe off the Lip Seal surface with a clean rag and lubricate it generously with the supplied lubricant, O-Ring grease or petroleum jelly.

Piston Rod U-Cup Lip Seal (#24):

1. Remove the old U-Cup Lip Seal from the seal groove with a bent paper clip or pick using care not to scratch the inside walls of the seal groove with the wire hook.
2. Clean out the seal groove and install a new U-Cup Lip Seal. Be sure the Lips are facing the right direction and are not twisted in the groove. See the sketch on page #9.

WARNING

The Lip Seals #23 and #24 look alike, but they are different, DO NOT mix them up.

3. Carefully wipe off the seal surface with a clean rag and lubricate it generously with the supplied lubricant, O-Ring grease or petroleum jelly.

Plunger Wiper Seal (#25):

1. Use a bent paper clip to pick out the felt Wiper Seal out of its groove in the Body Cap (#2).
2. Clean out the groove and insert a new felt Wiper Seal. Saturate the new felt Wiper Seal with oil.

Return Cylinder O-Ring Gasket (#26):

1. Place a new O-Ring Gasket in the groove on top of the Return Cylinder when you reassemble the Driving Blade Assembly.
2. Wipe off the O-Ring Gasket seal surface and lubricate it generously with the supplied lubricant, O-Ring grease or petroleum jelly.

5

REASSEMBLING THE STAPLER:

1. Be sure the Rubber Seat, Support Ring and Cylinder are installed in the Body and are facing the correct way.
2. All seal surfaces must be clean and lubricated generously with the supplied lubricant, O-Ring grease or petroleum jelly. Replace any part that shows signs of wear.
3. Use care when installing the seals into their respective cavities. Be sure the Seals are contained in their groove and do not come out as the parts slide together. Generous cavity lead in chamfers have been provided to help Seal installation.
4. Carefully insert the Piston Rod into the return Cylinder and screw the Piston onto the rod. Be sure the Piston is facing the correct way, ears up, hex down.
5. Assemble the Driving Blade, Dowel Pin and Jam Nut on to the Piston Rod.
6. Insert the Driving Blade Assembly up into the bottom of the Stapler Body Cylinder.
7. Be sure there is a new O-Ring Gasket in the top groove of the Return Cylinder.
8. Insert the Plunger into the top cavity of the Body. Line up the holes and install the three Plunger retaining screws. It is important that the three 10-32 screws are tight or air leakage will occur.
9. Position the Safety Yoke in the Plunger groove.
10. Install the body Cap and Plunger Rubber Cap.
11. Turn the Stapler upside down. Install the Rubber Bumper, Staple Channel Assembly and Adapter Foot. Be sure to align up the Driving Blade with the slot in the Foot before the Stapler is closed up.

12. NEVER FIRE THE NAILER WITHOUT THE RUBBER BUMPER INSTALLED, IT WILL DAMAGE THE NAILER.

TO CLEAR A NAIL JAM:

1. It helps to tap the Driving Blade back to the retracted position before trying to remove a jammed Staple. The spare Driving Blade works best for this.
2. Try to pull the jammed Staple out of the gate with a pair of long nose pliers. If this does not work, remove the four (4) cap screws holding the Foot, Gate and Staple Channel Assembly together.
3. Separate the Foot and gate with a screw driver just enough to clear out the jammed Staple.
4. Put thread locking compound on all screws and reassemble the components.